

TABLE OF CONTENTS

Product Features.....2
Safety Pre-Cautions.....4
Serial Number and Combination.....4
Manual Lock—Opening Instructions.....5
6120 Motorized Electronic Lock—Opening Instructions.....6
Z-02 Direct Drive Electronic Lock – Opening Instructions.....6
All Electronic Locks—Changing Combinations.....7
All Electronic Locks—Add or Delete Additional Users.....8
S&G 6120 Electronic Lock—Battery Replacement.....9
S&G Direct Drive Electronic Lock—Battery Replacement.....9
Moving Your Safe.....9
Removing the Safe from Pallet.....10
Placement of Your Safe.....10
Anchoring Your Safe.....11
Door Adjustors.....11
Loading Your Safe.....12
Cleaning and Maintaining Your Safe.....12
Lost Combination and Keys.....12
Troubleshooting Guide.....13
Frequently Asked Questions.....15
Warranty Claims and Repairs.....16



- A** Center Divider
- B** Detent Rod (select models)
- C** Door Adjuster (inside door jamb)
- D** Door Panel (accessory panel on select models)
- E** Electric Outlet (select models)
- F** Flex Gun Rack
- G** Flex Rack Cover
- H** Light Switch (select models)
- I** Locking Bolts
- J** Puck Lights (select models)
- K** Security, Fire, and Serial Number Label
- L** Side Shelves
- M** Top Shelf



- | | |
|---|------------------------|
| A Brand Name | F Hinge Side |
| B Combination Dial | G Model Name |
| C Electronic Access Hole (in back of safe) | H Open Side |
| D Handle Hub | I Pinstripe |
| E Handle Spoke | J Serial Number |

Congratulations on your purchase of your new high quality security safe designed and built by America's #1 gun safe company—Liberty Safe! To insure proper set up and installation, **PLEASE READ THIS USE AND CARE MANUAL** before opening your safe.



SAFETY PRE-CAUTIONS

The safe door is heavy. Do not open the door with the safe on an uneven or unstable floor. Hanging on an open door may cause the safe to tip forward when not lag-bolted to the floor, resulting in serious injury or death to yourself or others. If you have or have occasion to have small children in your home, please make sure you never leave your safe unsecured. It is possible for small children to climb inside your safe and become locked in. This could result in serious injury or death.

PACKAGING MATERIALS

After opening the safe, please remove the door's corner protectors. The fire seal is also covered with a black protective shipping tape. Please remove tape before using the safe.

INSPECT YOUR SAFE

Inspect your safe for shipping damage as soon as you receive it. If you find any damage, please contact the delivery company (or carrier) immediately. Any damage not noted upon delivery must be reported within fifteen (15) days or there will be no recourse.

SERIAL NUMBER & COMBINATION (See opening instructions before proceeding)



PLEASE NOTE: If your safe has been installed with an S&G Electronic Lock, use the Electronic Lock Opening Instructions on page 4 before proceeding.

Your safe's **serial number** is located in two (2) locations on the safe. One is located on the top of the safe, back right side. The second is located just inside the door by the chrome locking bolts. Compare the serial number in this manual with the serial number on the safe. All serial numbers should match. If they do not, contact your local dealer or Liberty Safe immediately. **You will need your safe serial number when contacting customer service about your safe.**



PLEASE NOTE: Record your safe's serial number and combination and store in a secure location ***OTHER THAN YOUR SAFE***.

MANUAL LOCK—OPENING INSTRUCTIONS (FIRST TIME)

The combination lock on your safe has been set randomly at the factory. Most safes come standard with a key-locking dial. To unlock the dial, insert the dial key and turn key a half a turn clockwise. Turn the dial to the right (clockwise). The dial should stop at about "87". Turn safe handle and open door. **With door open**, you can now verify your combination.



PLEASE NOTE: If the dial does not stop at "87" and continues to spin freely, the lock has been activated and you will need to **OPENING THE COMBINATION** (see paragraph below) with the door closed.

EXTENDING BOLTS BEFORE OPENING THE COMBINATION

To verify that your safe combination works it is recommended to test it once **with the door open**. If there are problems, it is easier to service the lock or mechanism with the door open. Before verifying your combination; while the door is open turn the handle counterclockwise to extend the locking bolts. Some models are equipped with a "bolt detent" mechanism that keeps the handle from turning while the door is open. To activate the bolt detent and release the handle locate the 5/16" bolt detent rod underneath the door (see "Safe Features" pg 2). Push in and hold the detent. Turn the handle counterclockwise and extend the locking bolts (see "Safe Features" pg 2). Make sure the locking bolts extend all the way out until they stop. **Keep door open while OPENING THE COMBINATION**.

OPENING THE COMBINATION

The lock requires accurate alignment with opening index (located at twelve o'clock on the dial ring). Always turn the dial slowly and steadily when entering your combination to avoid passing your numbers. **Never spin the dial rapidly back and forth as this may cause damage to the lock**. If you go past any number - even if by only a half a number - the entire combination must be re-dialed. To open your combination, follow the five steps below. Copy your combination numbers from page 2 to the spaces below.



Step 1
Turn the dial counterclockwise (**LEFT**) at least **4 times** stopping on the 1st number at the index mark.

1st# _____



Step 2
Turn the dial clockwise (**RIGHT**) passing the 2nd number twice. Stop on it the 3rd time.

2nd# _____



Step 3
Turn the dial counterclockwise (**LEFT**) passing the 3rd number once. Stop on it the 2nd time.

3rd# _____



Step 4
Turn the dial clockwise (**RIGHT**) until the dial stops (about **87**). You will feel some resistance at about 95. Keep turning until the dial completely stops at about 87.

Step 5 – If combination is entered correctly, you will be able to turn the safe handle.

⚠ IF COMBINATION DOES NOT WORK, DO NOT CLOSE DOOR! Try Again. Refer to the TROUBLE SHOOTING GUIDE in the back of this manual for more help.

CHANGING COMBINATIONS ON MANUAL LOCKS

It is inadvisable for anyone other than a CERTIFIED LOCKSMITH to change the combination on a manual lock. Changing the combination by anyone other than a certified technician will void the lock portion of your warranty. Call your dealer or Customer Service Representative (CSR) at Liberty Safe (800) 247-5625, press 0, for help locating an approved locksmith.

S&G MOTORIZED 6120 ELECTRONIC LOCKS—OPENING INSTRUCTIONS



⚠ WARNING! All Electronic locks are set at the factory to 123456 #. For security purposes, you should change this combination to your own, new combination number. (See instructions below)

⚠ Before entering your electronic lock combination, center the handle between left and right stop points. **If the handle or lock mechanism is pressuring the lock, it may not open the lock.**

⚠ Before entering your electronic lock combination, remove any static charge you may have by touching your finger to the body of the safe. **Discharging static electricity into the lock can damage it and prevent proper operation.**

Enter your 6 digit combination **followed by the pound (#) sign**. When each number is pressed, the lock will chirp and the red LED on the keypad will momentarily light up. After pressing the # sign, you should hear the lock retract inside the door, indicating the lock has opened and it is okay to turn the handle and open the safe door. You have **6 seconds** to turn the handle. If you wait longer than 6 seconds, the lock will re-lock and you will need to enter the code again. If you experience any problems opening your safe, refer to the Trouble Shooting section in this manual. If you pause more than 10 seconds between each number the lock will assume you do not wish to continue and will reset itself. If you press an incorrect button when entering the code, press the star (*) button and start again with the first number in the code. **As a security feature, if 4 incorrect codes are entered in a row, your lock will stop accepting combinations for a period of 15 minutes.**

To lock your safe, close the door and turn the handle until it stops. You should hear a 'click' indicating the lock bolt has dropped into place. Check by trying to open the door.

S&G DIRECT DRIVE ELECTRONIC LOCKS – OPENING INSTRUCTIONS

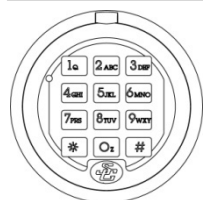

⚠ WARNING! All Electronic locks are set at the factory to 123456 #. For security purposes, you should change this combination to your own, new combination number. (See instructions below)

⚠ Before entering your electronic lock combination, center the handle between left and right stop points. **If the handle or lock mechanism is pressuring the lock, it may not open the lock.**

⚠ Before entering your electronic lock combination, remove any static charge you may have by touching your finger to the body of the safe. **Discharging static electricity into the lock can damage it and prevent proper operation.**

To open the Lock

Make sure the keypad is turned counterclockwise to stop. Press the code digits or letters in order, followed by #. Then, within six seconds, turn the keypad clockwise about 70 degrees (2 o'clock position), until it comes to a positive stop. **Do not put any pressure on the safe handle until after the keypad has been turned.**

To lock your safe, close the door and turn the handle until it stops. Turn the keypad back counterclockwise to stop.

After you have changed the combination on your electronic lock to your own unique combination, please fill in this combination on your warranty card and return to Liberty Safe. As part of our continuing service, a record of your combination by serial number is kept on file at Liberty Safe. If you lose your combination it can be restored to you for a \$25.00 research fee provided you have informed Liberty of the new combination code and you meet the documentation requirements. See the warranty for more details.

WARNING! Please keep door open when changing Electronic Combination!

CHANGING COMBINATION ON ELECTRONIC LOCKS

All code change procedures begin by pressing **SG*** (the same as **74***), followed by the existing six-digit master code and the pound (#) sign. When entered properly, the lock immediately chirps (🔊🔊🔊🔊) **five times**. If the lock emits a series of closely spaced chirps (almost a continuous tone) you have made a mistake and must start again. *Remember: always keep safe door open when making programming changes so you can verify that your new combination works before closing the safe door.*

TO CHANGE THE MASTER CODE ON THE S&G ELECTRONIC LOCK

Press **SG*** (_____ #) 🔊🔊🔊🔊 **1*** (_____ #) 🔊 (_____ #) 🔊
(7 4) existing master code new master code new master code

After each time the pound (#) key is pressed, the lock chirps to acknowledge the entry. Wait for the chirps before proceeding. If a long series of closely spaced chirps (almost a continuous tone) sounds after pound (#) key is pressed, the new user code will not be accepted and the old code will remain. You will need to start over.

TO ENTER OR CHANGE A USER CODE ON THE S&G ELECTRONIC LOCK

Press **SG*** (_____ #) 🔊🔊🔊 (user ID) * (_____ #) 🔊 (_____ #) 🔊
(7 4) existing master code new user code new user code

After each time the pound (#) key is pressed, the lock chirps to acknowledge the entry. Wait for the chirps before proceeding. If a long series of closely spaced chirps (almost a continuous tone) sounds after pound (#) key is pressed, the new user code will not be accepted and the old code will remain. You will need to start over.









For instance, if you want to enable the #2 user code (user ID codes are 2 thru 8; 1 is always the master code) to open the lock with a code of 4 4 6 6 3 3, you will use the following procedure:

Press **SG*** (_____ #) **2*** (4 4 6 6 3 3 #) 🔊🔊 (4 4 6 6 3 3 #) 🔊
(7 4) existing master code

The same procedure would change the existing #2 user code to 4 4 6 6 3 3

TO DELETE A USER CODE

You may find that a particular user code is no longer needed. It is a good security policy to remove any unused codes. To do so, follow this procedure:

Press **S G * (_ _ _ _ _ #)**     (user ID 2 thru 8) * #   #  
(7 4) existing master code

After each time the pound (**#**) key is pressed, the lock chirps to acknowledge the entry. Wait for the chirps before proceeding. If a long series of closely spaced chirps (almost a continuous tone) sounds after pound (**#**) key is pressed, the new user code will not be deleted and the old code will remain. You will need to start over. For a copy of the complete programming instructions for the S&G 6120 Motorized or Direct Drive Z-02 Electronic Lock call Customer Support at **(800) 247-5625 and Press 0**. To use our Fax-on-Demand service and have the instructions faxed to you call **(801) 465-5950**.

CHANGING BATTERIES IN ELECTRONIC LOCKS

Battery life is based on how much the electronic lock is used. The lock will emit several short chirps when battery power is getting low. S&G only recommends using **Duracell® 9V Alkaline Batteries** for best performance and for all replacements. The memory chip in the lock itself retains the lock codes (both master and user codes) during battery changes and even if the battery goes dead for an extended period of time. A weak battery may cause the lock to not open, even though beeps occur. Replace with fresh batteries at regular intervals to insure best performance.

BATTERY REPLACEMENT - S&G 6120 LOW PROFILE ELECTRONIC KEYPAD



Step 1—Remove the battery compartment from underneath the bottom of the keypad. Catch the small notch and pull the housing slightly toward the front of the keypad. Slide down and pull out.

Step 2—Open holder and remove old battery. Notice notches in top of battery compartment.

Step 3—Replace the battery with a **Duracell® 9V Alkaline Battery**. Match the large notch in the compartment with the large contact of the battery. Slide and click back into place.

BATTERY REPLACEMENT - S&G 6120 ELECTRONIC DUAL-BATTERY KEYPAD

Step 1—Remove the keypad from its mounting base. This can be done by pulling the top of the keypad housing away from the base. Support the keypad housing so that the wires, which are attached to its circuit board, are not pulled or stressed. **DO NOT LET THE KEY PAD HANG FROM ITS WIRES.**

Step 2—Turn the keypad over and remove both batteries. This is best done by grasping the bottom of a battery and pulling it gently away from the keypad circuit board. Do not use any type of tool to pry a battery from its holder.

Step 3—Install new batteries by pushing them directly into the battery connectors attached to the keypad circuit board. It is important to support the connectors so they will not become bent during battery insertion. The connectors are designed to make it very difficult to install a battery incorrectly. Pay close attention to battery polarity so as not to damage a connector by forcing a battery in backwards.

NOTE: The S&G 6120 standard profile electronic lock with dual battery keypad will operate with just one 9-volt alkaline battery attached to either connector. This is only recommended under emergency conditions when a second replacement battery is not available. Using a single battery will not harm the lock in any way.

BATTERY REPLACEMENT – S&G DIRECT DRIVE ELECTRONIC KEYPAD

Step 1—Pull the blue tab at the top of the keypad toward you slightly. It is not meant to separate from the keypad. Once it's out, carefully turn the keypad ring counterclockwise to stop. Then pull the ring away from its base far enough to expose the battery compartment.

Step 2—Put your finger in the battery compartment, and carefully pull out the battery. There should be enough room to place your finger on the side of the old battery and slid it out. Disconnect the old battery.



Step 3—S&G strongly recommends Duracell® brand alkaline batteries. No matter what brand is used, the battery must be alkaline. Align the battery and connector terminals, and snap the battery to the connector.

Step 4—Carefully slide the battery behind the keypad (wires & connector face down), into the cavity that is designed to hold it. Be sure the battery has dropped all the way to the bottom of the cavity.

Step 5—Battery wires should not be showing. If they are, gently place them into the cavity. Make sure it is not in a position to be caught between the keypad ring and the keypad base when the ring is pushed back against the base.

Step 6—Once the battery and any wires are safely positioned out of harm's way, push the keypad ring back up against the base, then turn it clockwise until the blue tab snaps back into its normal position.

Check your lock operation at least three times with the safe door open before closing it.

MOVING YOUR SAFE



SAFETY PRE-CAUTIONS

Before moving you safe, make sure you have completely tested the combination and lock to assure it will open properly prior to removing the safe from the pallet and to its final location. Safe doors are NOT designed to be removed due to possible serious injury. Never move the safe with the door open. Do not open the door with safe lying down. The safe's door should never be removed. Safes are very heavy and awkward to handle. Only use of proper moving equipment by a trained professional is recommended. Using a standard refrigerator dolly is very dangerous and can cause injury or death.

REMOVING THE SAFE FROM PALLET

With the safe upright and open, pry up the black plastic caps on the floor to expose the mounting bolts (note: some models require you to lift the access panels on both sides of the floor to expose the black plastic caps). Use a 9/16" ratchet to remove the bolts. **Caution: Have someone steady the safe while removing the safe from the pallet to prevent the safe from tipping forward.** Close and key-lock the door to prevent accidental opening while removing the safe from the pallet to the final location. Make sure you have adequate help to move the safe off its pallet. Carefully slide the safe off the pallet until one edge is resting on the floor. While the safe is tilted on its edge, remove the pallet out from under the safe. Carefully lower the safe back to its upright position.

PLACEMENT OF YOUR SAFE

Before moving your safe, verify the load bearing weight of the floors and stairs, and types of flooring the safe will be moved over (tile, wood, and other flooring can be damaged by the weight of the safe). To determine whether or not your safe will make it through doorways, stairs or corners take the empty safe box and see if it will fit all the way through to its final location.



Proper installation and anchoring are critical to the security and fire performance of your safe. Make sure you consider the following:

- Install near a load-bearing wall as a precaution to supporting the weight of the safe.
- To help protect the exterior finish of your safe, install inside your home in a dry location where there is climate control (heat in the winter and cooling in the summer).
- Depending upon the fire safe you've purchased, it has been designed to withstand a certain amount of heat during a fire. The safe's fire rating depends upon the number of layers of fireboard and BTU rating. Generally speaking, fire safes perform better in lower levels of a home (like the basement) where fire temperatures are lower. Additionally, placement of your safe away from potential hot spots (areas where flammable materials are stored) will improve your chances that your safe and its contents will perform better in a home fire. No safe is completely fireproof. If the fire reaches a high enough temperature for long periods, fire damage may occur.
- To store photographs, negatives, CD's or other electronic media, a Media Cooler Storage unit inside your safe is recommended for heat sensitive items.

ANCHORING YOUR SAFE

To achieve the highest level of security and safety possible, **anchor your safe securely to the floor**. We recommend placing a protective barrier (such as a piece of carpet, treated wood or rubber mat) between the safe and floor to prevent scratching of the safe surface, which could lead to rust. Before anchoring safe, make sure the safe is level. Use redwood door shims to adjust safe level so the door has the desired swing. Use appropriate hardware for the wood or cement surface you are anchoring to. Anchoring kits with instructions are available from your dealer. While most safes are UL Listed as Residential Security Containers (RSC), given enough time it is possible for a thief to break into a safe. Securing it to the floor helps secure and prevent removal of the safe by thieves.

DOOR ADJUSTORS

Most safe models have two door adjustors for tightening or loosening the door. These adjustors are located just inside the left side of the safes doorjamb. After removing the shipping protectors, close the door and extend the bolts. Pull out on the door handle to feel the tightness. If there is play in the door, you will need to adjust the slide. Using the supplied hex wrench, loosen

the two (2) door adjuster mounting screws. Slide the adjuster up to loosen the door, down to tighten the door. Re-tighten screws and check door again for fit. When properly adjusted, you should feel slight resistance when extending the door bolts. Only slight movement should be felt with the door shut. **Caution: Do not adjust door too tight. This may cause wear on both the door pins and locking mechanism. If your door has a tendency to self-open (the bolts retract by themselves), the door adjusters may be too tight.**

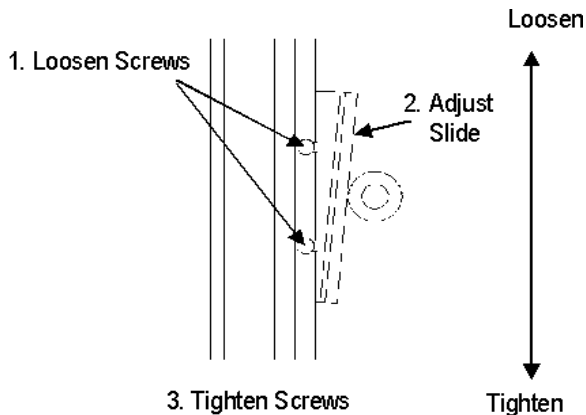

USING & MAINTAINING YOUR SAFE

LOADING YOUR SAFE

- When putting guns into your safe, make sure they rest securely against the cutouts provided to prevent accidental tipping when the door is closed.
- Store documents in the bottom of the safe for greatest protection against fire damage.
- Store ammunition separately from valuables.
- If you are storing electronic media, use a Media Cooler to provide additional protection (See your local dealer or visit www.libertysafe.com).
- Do not put anything in your safe that will put pressure against the door when it is closed.
- If you live in a humid environment, it is recommended that you use a **dehumidifier** or **desiccant** to protect the contents from rust or mildew. Dehumidifiers and other moisture reducing products suitable for your safe are available from your dealer. Dehumidifiers should be kept at least 1" away from side and back walls.
- Store heavy contents away from the middle of the shelf. Overloading shelves (46 + lbs.) can cause them to sag or break. Maximum weights vary by model. Contact Customer Support for complete details on max weights for each model.

ELECTRICAL OUTLET (Select Models)

Electrical outlets are installed only on select model safes. Before using the outlet some assembly is required

Step 1. Locate the power cord on the inside of the safe on the floor. Attach the female side of the cord to the electrical access hole in the back of the safe.

Step 2. Plug in the power cord to the back of the safe (see safe features for location of electrical access pg 3).



SAFETY PRE-CAUTIONS

CLEANING AND MAINTAINING YOUR SAFE

- **Manual Locks** – It is recommended that you have your manual lock serviced annually by a certified lock technician to maintain trouble-free service. Electronic locks do not require this service.
- **Chrome Locking Pins** – Once per year extend the bolts and wipe a small amount of grease along the bottom and front side of the pin.
- **Internal Locking Mechanism** – The advanced locking mechanism requires no maintenance. Opening the door panel of your safe by anyone other than a certified lock or safe technician may void your warranty.
- **Exterior** – Use a soft, non-abrasive cloth dampened with water to clean the surface of a gloss, powder coat or textured finish safe. Other materials may cloud or scratch the finish of your safe:
 - Logos and other graphic images must be wiped gently. Never rub or polish
 - The lock and handle have a protective coating to prevent tarnish. **DO NOT** use metal polishes or solvents for cleaning. Simply wipe off with a soft cloth.
 - Scratches and other blemishes may be touched up with a paint touch up kit available from your dealer.
- **Fire Seal** – The fire seal does not need maintenance unless it is ripped or destroyed.

If the seal becomes damaged, call for replacement pieces. The Palusol® fire seal used provides additional fire protection. Once the temperature reaches 212° it expands up to seven (7) times its flat size and fills the joints and gaps resisting penetration of smoke and heat.

LOST COMBINATION OR KEYS—ALL LOCK TYPES

The lock on your safe has been set with a randomly selected combination at the time of manufacturing. As part of our continuing service, a record of your combination by serial number is kept on file. To help us better serve you, please contact Customer Support at (800) 247-5625 when you change your combination or code.

If you lose your combination, you can retrieve a copy for a \$25.00 research fee, **provided you have not changed it from the original combination**. You must complete certain security and documentation requirements. If you lose your keys you can obtain a duplicate for \$5.00 each key, plus \$5.00 shipping and handling. Call a CSR at (800) 247-5625, press 0, or go to www.libertysafe.com to download a combination/duplicate key request form. To use our Fax-on-Demand service and have forms faxed directly to you call **(801) 465-5950**.

TROUBLE SHOOTING GUIDE

Problem	Possible Solution
Key Will Not Turn	Verify that the combination dial is set at zero before attempting to turn the key. Make sure key is fully inserted before attempting to turn key.
Combination Will Not Open the Safe	Check lock bolt pressure. Some free play should exist in the handle, left to right. Redial the complete combination stopping at "0" (before reaching "87"). Hold dial on "0" while rattling the handle left and right. Then turn the dial right until it stops at about "87". PLEASE NOTE: If your lock still does not open, it is possible that one or more of your numbers may be off slightly from those shown in this manual. The combination number may have shifted slightly during shipping. Try dialing 1 up or 1 down from each number in the combination. If it opens with a new number, update your combination in this book and report it to Liberty Safe (800) 247-5625, Press 0.
Combination Opens the Safe Intermittently	Check lock bolt pressure. Some free play should exist in the handle, left to right. Try dialing the combination again. Bolt pressure may be due to out of place interior shelves or improper personal storage (i.e. gun barrels, items too big for shelves).
Combination Dial Is Tight or Will Not Turn	Verify that the key-lock is unlocked (jagged edge of key will be facing up) before attempting to turn dial. Check lock bolt pressure. Some free play should exist in the handle, left to right. Bolt pressure may be due to out of place interior shelves or improper personal storage. Make sure the door is completely closed and the locking bolts are in the fully extended position. Normally dial tightness varies from safe to safe. Tightness of dial may increase or decrease as dial is being turned.

Combination Works But Handle Will Not Turn Verify that the dial has completely stopped (turning to the right) on or about "87" before turning the handle. Corner protectors (packaging material) may cause undue pressure on the locking bolts. To alleviate the pressure push in on the door while pulling out and turning the handle to open the safe. If the handle turns partially the bolts may be jammed or caught up. Try rotating the handle back and forth (left to right) until the bolts free up. Use a cotton cloth and light oil to rub each chrome locking bolt on the open and hinge side of the door.

Combination Works and Handle Turns But Safe Will Not Open Verify that the handle has been completely rotated in the open position before opening the door. Check the **Allen set screw** located on either the front (center of handle under sticker) or side of the handle hub for tightness. Some safes are installed with a unique handle clutch mechanism. Improper personal storage or over tightening the door adjusting mechanism may cause the clutch to temporarily engage. Try pushing in on the door while pulling out and turning the handle. You may have to repeat this step several times until door is open.

Door Rattles When Shut Refer to the Door Adjustment Procedures (pg. 8). Also, verify that the handle has rotated completely and that the chrome locking bolts are fully extended.

Door Will Not Shut Verify that the lock is unlocked and the chrome locking bolts are fully retracted. Make sure the interior shelves are pushed back as far as possible, and that the floorboard is pressed down to the bottom of the safe floor. The handle should travel the same distance with the door closed as it does with the door open.

Door Shuts But Will Not Lock Verify that the door is shut completely, the handle rotated completely and chrome locking bolts are extended to their locked position. Then rotate the dial to lock the safe. Verify that interior shelves are pushed back as far as possible, and that the floorboard is pressed down to the bottom of the safe floor.

Chrome Locking Bolts Do Not Retract to Close Door Verify that the dial is unlocked and has stopped on or about "87" before turning the handle. On models with electronic locks make sure the electronic lock is unlocked. Bolts may become dry and need oil. Use a cotton cloth and light oil to rub each bolt entirely, front & back of door.

Electronic lock will not open. 1. The locking mechanism of a safe can, under certain conditions, place pressure on the side of the lock's bolt. This is often caused by something inside the safe pressing against the door or by something caught between the safe door and its frame. When this occurs, the lock will not operate properly. To relieve side pressure on the lock bolt, move the safe's handle to the fully locked position, make sure the keypad is turned counterclockwise to stop, then re-enter a working code. The lock should open.

2. If the lock “chirps” when keys are pressed, but it will not open, the batteries may be drained to the point that they will not operate enough to open the lock. Follow the battery replacement procedure in this manual.

3. If the lock makes no sound when any of the keys are pressed, dead batteries are likely to be the cause. Follow the battery replacement procedure in this manual.

4. Your lock may be in penalty mode. If the lock interprets your button presses as four or more incorrect codes in a row, it will lock you out for fifteen minutes. If you press any keypad button within this fifteen minute period, the penalty timer increments to its full fifteen minute period all over again. Simply refrain from pressing any buttons for at least five minutes, they re-try your code.

FREQUENTLY ASKED QUESTIONS

Q. How does the key-lock work?

A. It is used to lock the dial from turning. You can lock the dial combination scrambled or open. Simply set the dial to “0”, insert the key and turn half a turn counterclockwise. This will lock the safe. To unlock, turnkey half a turn clockwise, remove the key and either redial combo or turn dial back to opening position.

Q. Can I change the safe’s combination?

A. If the safe is equipped with an electronic lock refer to the “Changing Your Combination” instructions in this manual. (The S&G operating instructions for bio-metric locks are included in your packet as well). If the safe is equipped with a mechanical dial lock you must contact a locksmith or your local dealer to have the combination reset.

Q. Why is the handle pointing in a different direction than it used to be?

A. The handle has a built in clutch mechanism. When the handle is forced it will slip left or right. To reset it simply force it back to its original position when locked.

Q. What is routine maintenance and who is qualified to do it?

A. Routine maintenance is to keep your safes lock is in good working condition and may prevent costly lockouts. Most locksmiths can perform the work. Make sure that they are familiar with Sargent & Greenleaf® group II locks.

Q. What if I lose my keys or combination?

A. A Duplicate Key/Combination request form must be filled out and faxed along with a copy of the sales receipt to: **(801) 465-5940**. You can print a form from our website www.libertysafe.com under the Support tab or have one mailed by calling our toll free customer service line at (800) 247-5625, press 4. To use our Fax-on-Demand service and have forms faxed directly to you call **(801) 465-5950**.

Q. Can an electronic lock be installed on the safe?

A. Yes. Contact your dealer for details.

WARRANTY CLAIMS

Please read carefully the safe warranty that accompanied your safe. If you encounter a problem that falls under the warranty coverage, simply call Customer Support at (800) 247-5625, press 0. You will be required to provide the serial number and proof of ownership if you have not sent in your warranty card.

WARRANTY REPAIRS

Repairs to your safe covered under your warranty should not be performed without the pre-authorization of a Liberty customer service representative. If there are any issues regarding your safe please contact a Liberty Safe Customer Support at (800) 247-5625. Solutions to frequently asked questions and issues can also be found in Trouble Shooting Guide in this booklet or on line at www.libertysafe.com. The cost of any repairs performed without pre-authorization will be the sole responsibility of the owner.

WATER AND FIRE DAMAGE

Your safe is not waterproof. Should your safe be exposed to fire or water, the fire insulation of your safe will be compromised. In this event, make sure to have your safe opened as soon as possible. If your safe included firearms, remove them and have them cleaned and lubricated as soon as possible. Do not continue to store items in a safe that has been compromised by water or fire. You should purchase a replacement model in either case.

INSURANCE COVERAGE

Liberty safe does not insure the contents of your safe. A homeowner's policy or other insurance coverage should be purchased in an amount sufficient to cover the contents. Most homeowner's policies require the purchase of riders or endorsements on items such as guns, jewelry coins and other valuable collectibles. Should damage occur to your valuables, a claim should be made with your homeowners insurance. Check with your local insurance company for possible discounts that may be available with your purchase.